

60 Hz Standard Capacity 4" Submersible Pumps

MODEL GS

5GS, 7GS, 10GS,
13GS, 18GS, 25GS



SPECIFICATIONS

Model	Flow Range GPM	Horsepower Range	Best Eff. GPM	Discharge Connection	Minimum Well Size	Rotation ^①
5GS	1.2 – 7.5	½ – 2	5	1¼	4"	CCW
7GS	1.5 – 10	½ – 3	7	1¼	4"	CCW
10GS	3 – 16	½ – 5	10	1¼	4"	CCW
13GS	4 – 20	½ – 3	13	1¼	4"	CCW
18GS	6 – 28	¾ – 5	18	1¼	4"	CCW
25GS	8 – 33	1 – 5	25	1¼	4"	CCW

① Rotation is counterclockwise when observed from pump discharge end.

"GS" SERIES MATERIALS OF CONSTRUCTION

Part Name	Material
Discharge Head	AISI 303 SS
Check Valve Poppet	AISI 304 SS
Check Valve Seal	BUNA, FDA compliant
Check Valve Seat	AISI 304 SS
Check Valve Retaining Ring	AISI 302 SS
Bearing Spider – Upper	Glass Filled Engineered Composite
Bearing	Urethane, FDA compliant
Klipring	AISI 301 SS
Diffuser	Glass Filled Engineered Composite
Impeller	AISI 304 SS
Bowl	AISI 304 SS
Intermediate Sleeve ^①	AISI 304 SS, Powder Metal
Intermediate Shaft Coupling ^②	AISI 304 SS, Powder Metal
Intermediate Bearing Spider ^①	Glass Filled Engineered Composite
Intermediate Bearing Spider ^②	AISI 303 SS
Bearing	Urethane, FDA compliant
Shim	AISI 304 SS
Spacer	AISI 304 SS, Powder Metal
Screws – Cable Guard	AISI 304 SS
Motor Adapter	AISI 303 SS
Casing	AISI 304 SS
Shaft	AISI 304 SS
Coupling	AISI 304 SS, Powder Metal
Cable Guard	AISI 304 SS
Suction Screen	AISI 304 SS

① Used on pumps over 24 stages.
② Used on models with 27 stages or larger.

AGENCY LISTINGS

Canadian Standards Association

Underwriters Laboratories
Classified ANSI/NSF 61-1992

Goulds Pumps is ISO 9001 Registered.

Goulds Pumps
 ITT Industries

FEATURES

- **Powered for Continuous Operation:** All ratings are within the working limits of the motor as recommended by the motor manufacturer. Pump can be operated continuously without damage to the motor.
- **Field Serviceable:** Pump can be rebuilt in the field to like new condition with common tools and readily available spare parts.
- NOTE: The Model GS has left hand casing threads.
- **Sand Resistant Construction:** Field proven over almost four decades, face clearance design and floating impellers for an extremely abrasion resistant configuration.
- **Stainless Steel Metal Parts:** AISI types 302, 303 and 304 are corrosion resistant, non-toxic and non-leaching.
- **FDA Compliant Non-Metallic Parts:** Impellers, diffusers and bearing spiders are constructed of a glass filled engineered compos-

ite. This material is corrosion resistant and non-toxic.

- **Discharge Head:** High profile precision cast 303 stainless steel for superior strength and durability. Cast in loop for safety line.

- **Motor Adapter:** Precision cast 303 stainless steel is extremely rigid for accurate alignment of liquid end to motor. Generous space for removal of motor mounting nuts with regular open-end wrench.

- **Bowls:** Stainless steel for strength and abrasive resistance.

- **Check Valve:** Built in check valve constructed of stainless steel and low compression, FDA compliant, BUNA rubber for excellent abrasive resistance and quiet, efficient operation.

- **Stainless Steel Casing:** Polished stainless steel is attractive and durable in the most corrosive water.

- **Hex Shaft Design:** Six sided shafts for positive impeller drive.

- **Shaft Coupling:** Exposed for ease of field alignment to motor shaft and to check pump rotation.

- **Urethane Upper and Middle Bearings:** Fluted design for free passage of abrasives and excellent resistance to sand damage.

- **Franklin Electric Motor:**
 - Corrosion resistant stainless steel construction through 2 HP, stainless steel casing with nickel plated gray iron end bells on motors over 2 HP.

- Built-in surge arrestor is provided on single phase motors through 5 HP.
- Stainless steel splined shaft.
- Hermetically sealed windings.
- Replaceable motor lead assembly.
- UL 778 recognized.
- NEMA mounting dimensions.
- Control box is required with 3 wire single phase units.

- Three phase units require a magnetic starter with three leg protection. Magnetic starter and heaters must be ordered separately.

- **Agency Listings:** All complete pump/motor assemblies are UL778 and CSA listed and complies with ANSI/NSF std. 61. All 4" Franklin Electric Motors are UL778 recognized.

ORDER NUMBER CODE

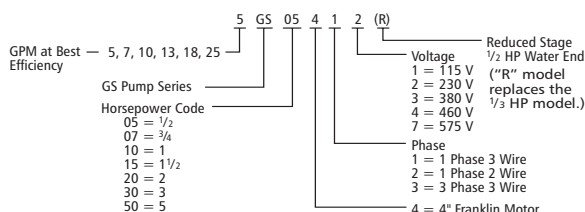

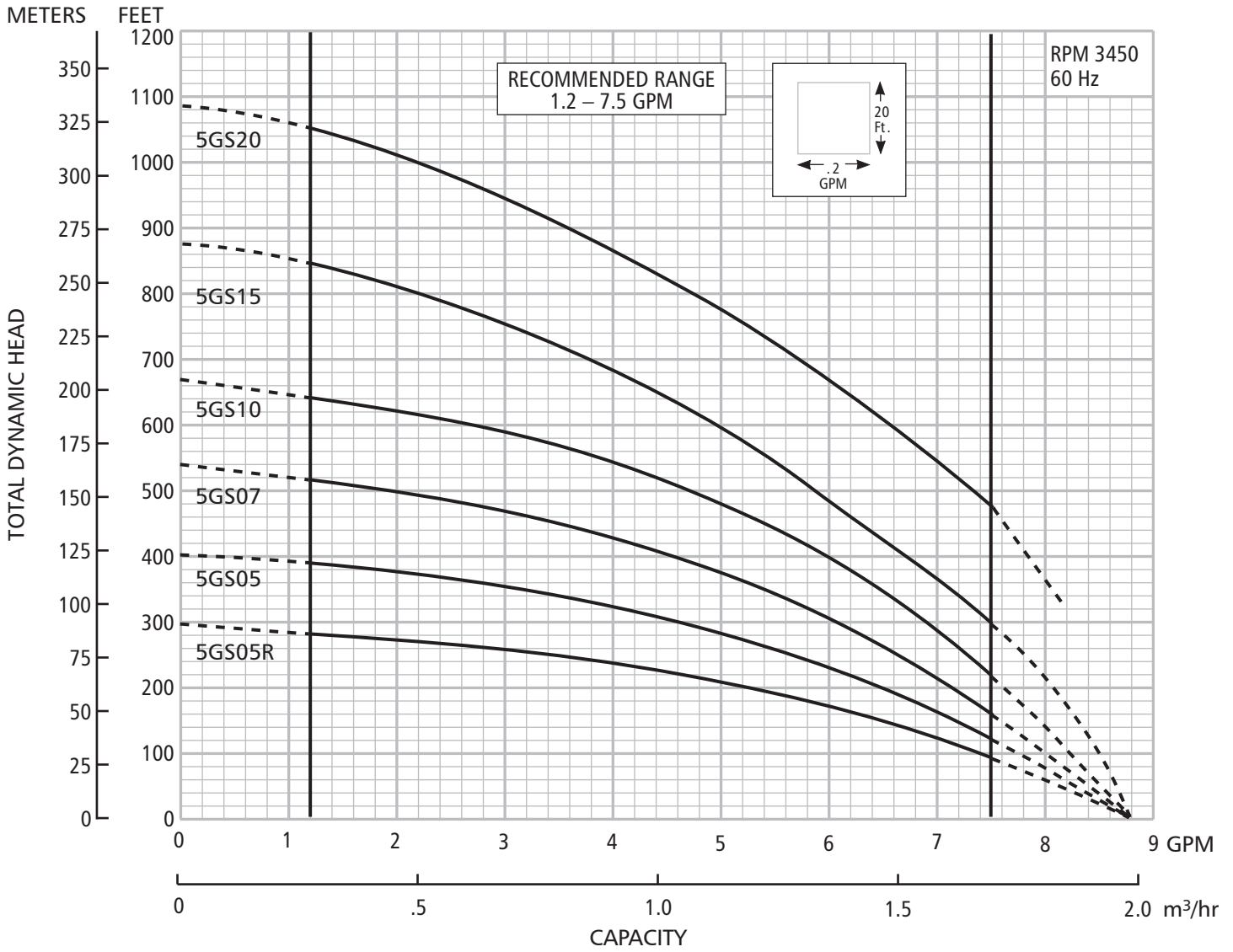

DIMENSIONS AND WEIGHTS

Model	HP	Phase	Stages	Length (inches)			Weight (lbs.)		
				W.E.②	Motor	L.O.A.③	W.E.	Motor	Total
5GS05412R,22,11,21①	1/8R①	1	9	12.4	9.5	21.9	7	19	26
5GS05412,22,11,21	1/2	1	12	14.5	9.5	24.0	8	19	27
5GS07412,22	3/4	1	15	16.5	10.7	27.2	9	21	30
5GS10412,22	1	1	20	20.0	11.8	31.8	11	24	35
5GS15412	1 1/2	1	26	25.3	13.6	38.9	14	28	42
5GS15422	1 1/2	1	26	25.3	15.1	40.4	14	31	45
5GS15432,34	1 1/2	3	26	25.3	11.8	37.1	14	24	38
5GS20412	2	1	33	30.1	15.1	45.2	17	33	50
5GS20432,34	2	3	33	30.1	13.6	43.7	17	28	45

① Reduced stage 1/2 HP pump/water end for low head applications. This model replaces the 1/2 HP water end.

② W.E. = water end or pump without motor.

③ L.O.A. = length of assembly – complete pump – water end and motor.

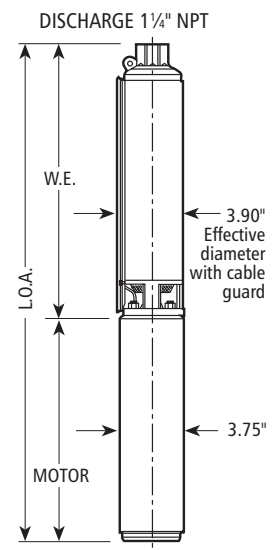

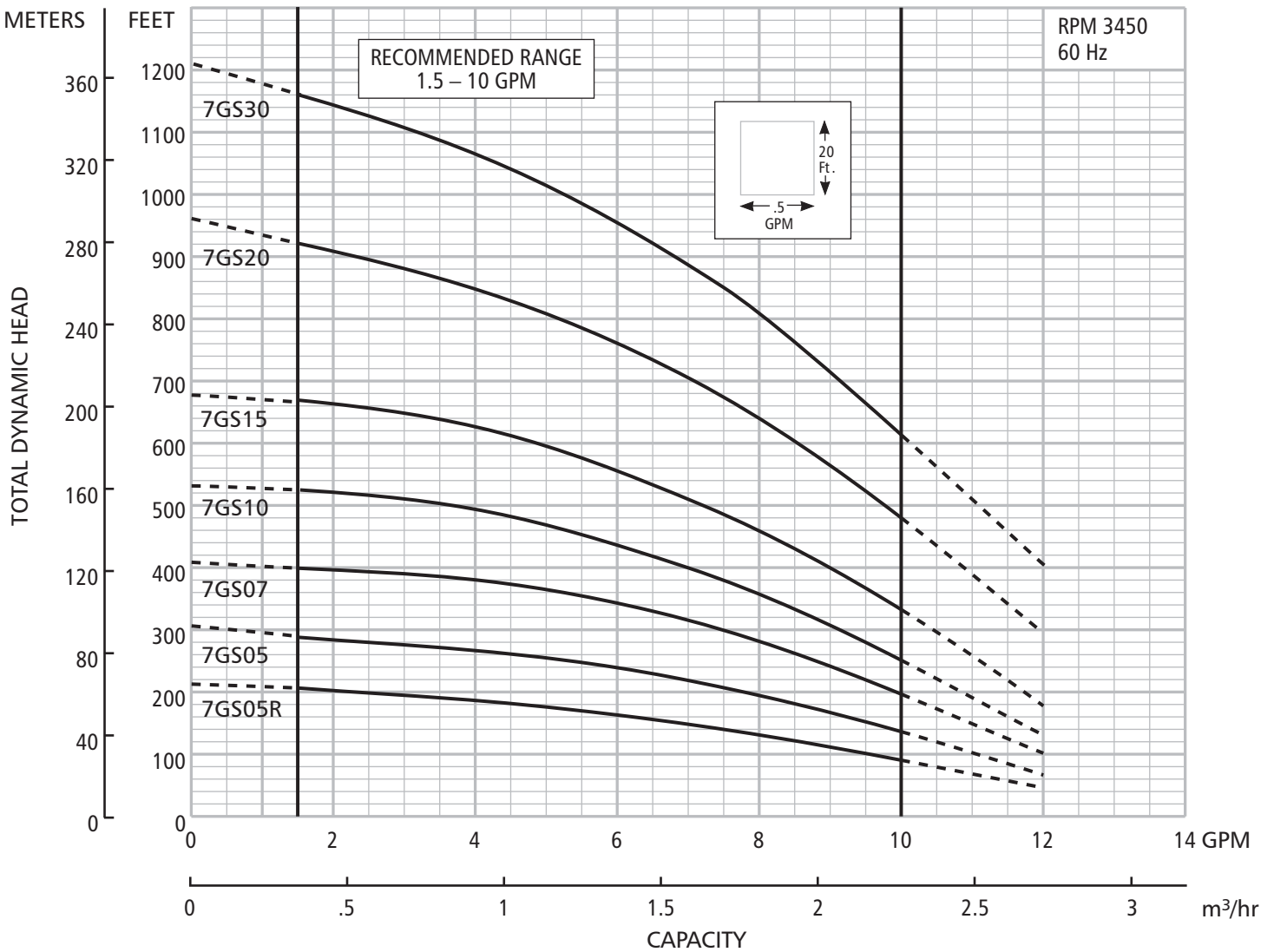

DIMENSIONS AND WEIGHTS

Model	HP	Phase	Stages	Length (inches)			Weight (lbs.)		
				W.E.②	Motor	L.O.A.③	W.E.	Motor	Total
7GS05412R,22,11,21①	½R①	1	7	11.1	9.5	20.6	6	19	25
7GS05412,22,11,21	½	1	10	13.3	9.5	22.8	7	19	26
7GS07412,22	¾	1	13	15.4	10.7	26.1	9	21	30
7GS10412,22	1	1	17	18.3	11.8	30.1	10	24	34
7GS15412	1½	1	22	21.9	13.6	35.5	12	28	40
7GS15422	1½	1	22	21.9	15.1	37.0	12	31	43
7GS15432,34	1½	3	22	21.9	11.8	33.7	12	24	36
7GS20412	2	1	27	26.6	15.1	41.7	15	33	48
7GS20432,34	2	3	27	26.6	13.6	40.2	15	28	43
7GS30412	3	1	34	31.6	19.1	50.7	18	41	59
7GS30432,34	3	3	34	31.6	16.1	47.7	18	35	53

① Reduced stage ½ HP pump/water end for low head applications. This model replaces the ½ HP water end.

② W.E. = water end or pump without motor.

③ L.O.A. = length of assembly – complete pump – water end and motor.

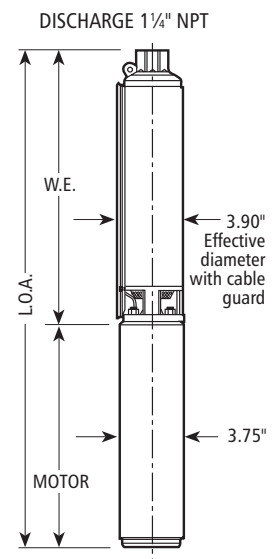

SELECTION CHART

Horsepower Range ½ – 1, Recommended Range 1.5 – 10 GPM, 60 Hz, 3450 RPM

Pump Model	HP	PSI	Depth to Water in Feet/Ratings in GPM (Gallons per Minute)																													
			20	40	60	80	100	120	140	160	180	200	220	240	260	280	300	340	380	420	460	500	540	580	620	660	700	740	780	820		
7GS05R	½R	0					9.7	8.7	7.6	6.2	4.3	2.0																				
		20			9.4	8.4	7.4	5.7	3.5	1.5																						
		30		9.2	8.2	7.0	5.4	3.4																								
		40	9.0	8.1	6.9	5.2	3.1																									
		50	7.7	6.5	4.8	3.0																										
		60	6.2	4.3	2.0																											
Shut-off PSI			82	74	65	56	48	39	30	22	13	4																				
7GS05	½	0							9.8	9.2	8.5	7.8	7.0	5.9	4.5	2.8																
		20					9.7	9.0	8.3	7.5	6.6	5.7	4.1	2.0																		
		30				9.5	8.9	8.2	7.3	6.4	5.4	4.0	1.5																			
		40		10.0	9.4	8.8	8.1	7.3	6.1	5.1	3.9	1.5																				
		50	10.0	9.3	8.6	8.0	7.1	6.0	4.8	3.3																						
		60	9.2	8.5	7.8	7.0	5.9	4.5	2.8																							
Shut-off PSI			121	113	104	95	87	78	69	61	52	43	35	26	17	9																
7GS07	¾	0										9.8	9.4	8.8	8.4	7.9	7.4	5.8	3.8													
		20								9.7	9.3	8.8	8.3	7.8	7.3	6.5	5.7	3.0														
		30							9.6	9.3	8.7	8.2	7.7	7.0	6.3	5.5	4.5															
		40					10.1	9.5	9.1	8.7	8.2	7.7	6.9	6.2	5.4	4.5	2.7															
		50			10.0	9.4	9.0	8.5	8.0	7.6	6.8	6.0	5.2	4.0	2.5																	
		60		9.8	9.4	8.8	8.4	7.9	7.4	6.7	5.8	5.0	3.8	1.5																		
Shut-off PSI				148	140	131	123	114	105	97	88	79	71	62	53	45	27	10														
7GS10	1	0												9.7	9.4	9.1	8.2	7.4	6.5	5.2	3.5											
		20											9.7	9.3	8.9	8.5	8.1	7.3	6.3	5.0	3.0											
		30									10.0	9.6	9.2	8.8	8.4	8.1	7.7	6.7	5.6	4.0												
		40								9.9	9.5	9.2	8.7	8.4	8.0	7.7	7.2	6.1	4.8	2.5												
		50							9.8	9.4	9.1	8.7	8.3	7.8	7.5	7.1	6.2	5.4	3.9													
		60						9.7	9.4	9.1	8.6	8.2	7.8	7.4	7.0	6.5	5.8	4.4	2.0													
Shut-off PSI							177	168	159	151	142	133	125	116	107	99	81	64	47	29	12											

Horsepower Range 1½ – 3, Recommended Range 1.5 – 10 GPM, 60 Hz, 3450 RPM

Pump Model	HP	PSI	Depth to Water in Feet/Ratings in GPM (Gallons per Minute)																													
			200	220	240	260	280	300	340	380	420	460	500	540	580	620	660	700	740	780	820	860	900	940	980	1020	1060	1100	1140			
7GS15	1½	0							9.8	9.3	8.7	8.0	7.3	6.4	5.4	4.1	1.8															
		20					10.1	9.8	9.2	8.5	7.9	7.2	6.4	5.3	3.8	1.5																
		30				10.0	9.8	9.5	8.8	8.2	7.4	6.7	5.7	4.5	2.8																	
		40			10.0	9.7	9.5	9.1	8.4	7.8	7.0	6.2	5.2	3.4																		
		50	9.9	9.6	9.4	9.0	8.7	8.0	7.4	6.5	5.6	4.2	2.3																			
		60	9.8	9.6	9.3	9.0	8.7	8.3	7.6	6.9	6.0	4.9	3.1																			
Shut-off PSI			206	198	185	176	168	159	142	124	107	90	72	55	38	20																
7GS20	2	0											9.8	9.3	8.7	8.4	7.8	7.1	6.3	5.4	4.5	3.5	2.2									
		20											9.8	9.3	8.7	8.4	7.7	6.9	6.2	5.3	4.3	3.2	2.8									
		30										9.9	9.5	9.0	8.5	7.9	7.2	6.4	5.7	4.4	3.7											
		40									10.0	9.7	9.2	8.7	8.3	7.5	6.7	6.0	5.2	4.1	3.0											
		50									9.9	9.4	8.9	8.5	7.8	7.2	6.3	5.5	4.7	3.5												
		60								10.0	9.6	9.1	8.7	8.2	7.4	6.6	5.8	5.0	4.0													
Shut-off PSI								268	251	234	216	199	182	165	147	130	113	95	80	61												
7GS30	3	0														9.8	9.5	9.2	8.7	8.3	7.9	7.4	6.8	6.2	5.4	4.7	3.9	3.0	2.0			
		20														9.8	9.4	9.2	8.7	8.3	7.8	7.2	6.7	6.2	5.3	4.5	3.7	3.3	1.7			
		30														10.0	9.6	9.2	8.8	8.5	8.0	7.5	6.9	6.3	5.7	4.8	4.1	3.2	2.3			
		40														10.0	9.7	9.4	9.0	8.6	8.2	7.7	7.2	6.6	5.9	5.2	4.4	3.6	2.7	1.7		
		50														9.9	9.5	9.2	8.7	8.4	7.9	7.4	6.8	6.3	5.5	4.8	3.9	3.1	2.2			
		60														10.0	9.7	9.3	9.0	8.6	8.1	7.6	7.0	6.5	5.8	5.1	4.2	3.4	2.5	1.5		
Shut-off PSI												320	303	286	268	251	234	216	199	182	165	147	130	113	95	78	61	43	27			

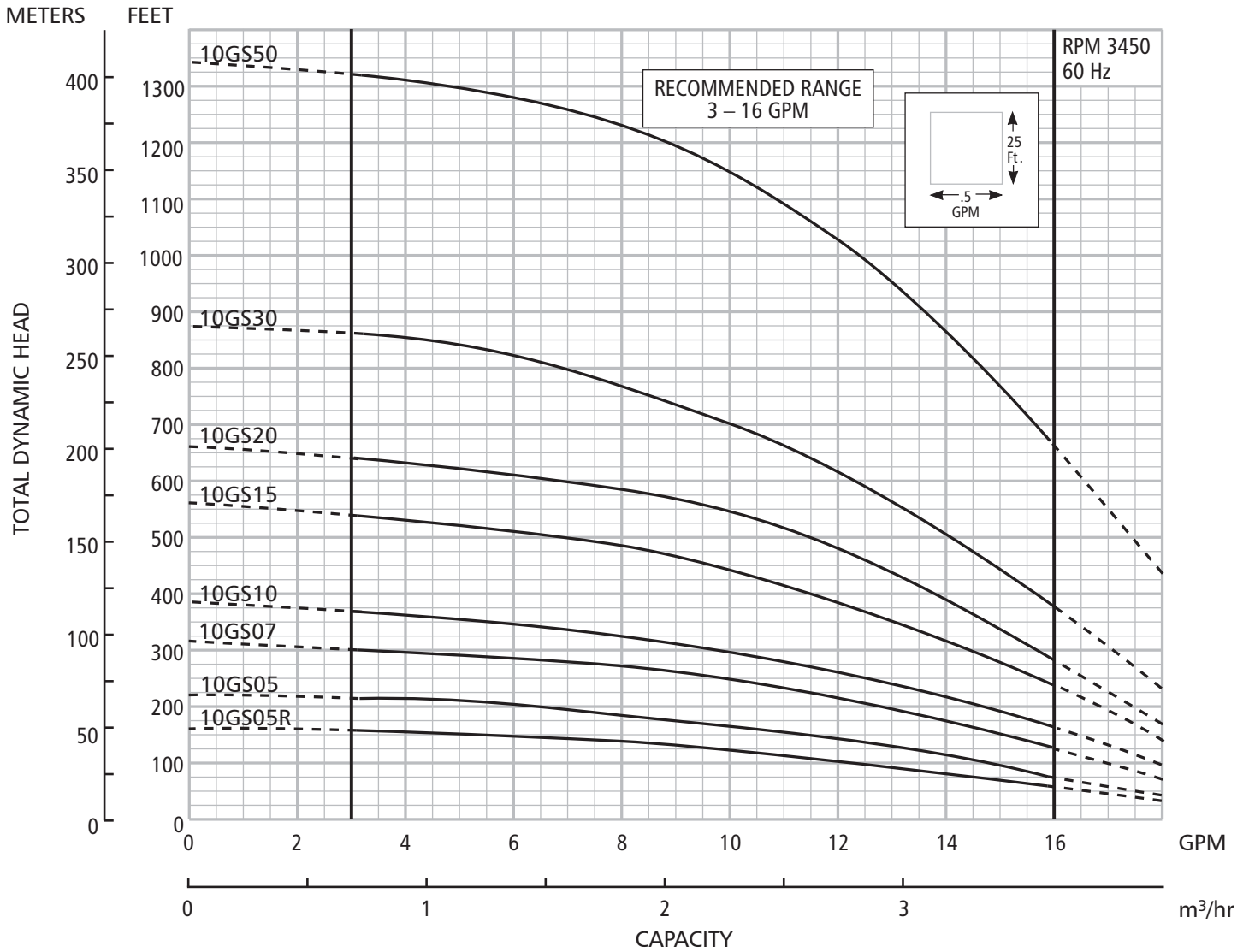

DIMENSIONS AND WEIGHTS

Model	HP	Phase	Stages	Length (inches)			Weight (lbs.)		
				W.E.②	Motor	L.O.A.③	W.E.	Motor	Total
10GS05412R,22,11,21①	½R①	1	5	9.6	9.5	19.1	6	19	25
10GS05412,22,11,21	½	1	7	11.0	9.5	20.5	7	19	26
10GS07412,22	¾	1	10	13.0	10.7	23.7	8	21	29
10GS10412,22	1	1	12	14.4	11.8	26.2	9	24	33
10GS15412	1½	1	17	17.9	13.6	31.5	11	28	39
10GS15422	1½	1	17	17.9	15.1	33.0	11	31	42
10GS15432	1½	3	17	17.9	11.8	29.7	11	24	35
10GS20412	2	1	20	20.0	15.1	35.1	12	33	45
10GS20432,34	2	3	20	20.0	13.6	33.6	12	28	40
10GS30412	3	1	27	26.0	19.1	45.1	15	41	56
10GS30432,34	3	3	27	26.0	16.1	42.1	15	35	50
10GS50142	5	1	42	36.3	28.2	64.5	20	70	90
10GS50432,34	5	3	42	36.3	22.2	58.5	20	55	75

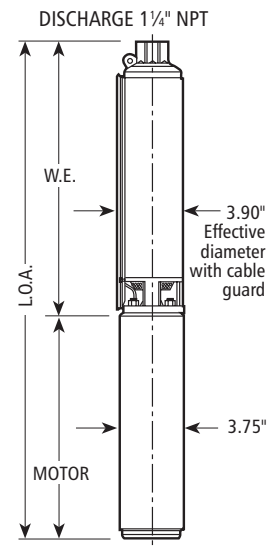

① Reduced stage ½ HP pump/water end for low head applications. This model replaces the ½ HP water end.

② W.E. = water end or pump without motor.

③ L.O.A. = length of assembly – complete pump – water end and motor.

SELECTION CHART

Horsepower Range ½ – 3, Recommended Range 3 – 16 GPM, 60 Hz, 3450 RPM

Pump Model	HP	PSI	Depth to Water in Feet/Ratings in GPM (Gallons per Minute)																																
			20	40	60	80	100	120	140	160	180	200	220	240	260	280	300	340	380	420	460	500	540	580	620	660	700	740	780	820					
10GS05R	½	0			15.6	14.0	12.4	10.4	6.5																										
		20	15.4	13.5	11.5	9.2	6.0																												
		30	13.0	11.1	8.0	4.0																													
		40	11.0	7.9	3.0																														
		50	7.0																																
		60																																	
Shut-off PSI			61	53	44	34	26	18	10																										
10GS05	½	0				16.0	15.3	14.3	12.8	11.3	9.0	6.4																							
		20		15.9	14.9	13.8	12.5	10.8	8.3	4.8																									
		30	15.7	14.6	13.5	12.3	10.5	7.8	4.0																										
		40	14.5	13.4	12.0	10.3	7.5	3.0																											
		50	13.0	11.5	9.8	7.2																													
		60	11.3	9.0	6.4																														
Shut-off PSI			89	81	72	63	55	46	37	29	20	11																							
10GS07	¾	0					16.0	15.2	14.3	13.4	12.5	11.5	10.3	9.0	7.0	4.0																			
		20				15.8	15.0	14.0	13.0	12.3	11.2	10.2	8.5	6.0																					
		30			15.7	14.8	13.9	12.8	12.0	11.0	9.8	8.2	5.5																						
		40		15.6	14.7	13.8	12.7	11.9	10.8	9.7	8.1	5.2																							
		50	15.3	14.4	13.5	12.6	11.6	10.5	9.4	7.5	4.8																								
		60	14.3	13.4	12.5	11.5	10.3	9.0	7.0	4.0																									
Shut-off PSI			130	121	113	104	95	87	78	69	61	52	43	35	26	17	9																		
10GS10	1	0						15.8	15.2	14.5	13.7	12.8	12.0	11.0	10.0	6.7																			
		20					15.7	14.9	14.3	13.5	12.7	11.7	10.6	9.6	8.1	6.5																			
		30				16.0	15.6	14.8	14.2	13.3	12.5	11.6	10.4	9.4	7.8	5.5	3.0																		
		40			16.0	15.5	14.7	14.1	13.2	12.4	11.5	10.3	9.1	7.4	5.0	3.0																			
		50			15.3	14.6	13.9	13.0	12.3	11.3	10.1	8.9	7.0	4.3																					
		60	15.8	15.2	14.5	13.7	12.8	12.0	11.0	10.0	8.6	6.7	4.0																						
Shut-off PSI			158	150	141	132	124	115	106	98	89	81	72	63	55	46	37	20																	
10GS15	1½	0										15.7	15.3	14.8	14.4	13.3	12.2	10.9	9.3	7.1	3.0														
		20										16.0	15.6	15.2	14.7	14.3	13.7	13.2	11.9	10.6	9.0	6.5													
		30										15.9	15.5	15.2	14.6	14.2	13.5	13.1	12.6	11.3	9.7	7.6	4.0												
		40										15.8	15.5	15.1	14.6	14.2	13.5	13.0	12.5	11.8	10.3	8.8	6.0												
		50										15.7	15.4	14.9	14.5	14.0	13.4	12.8	12.3	11.7	11.0	9.4	7.4	3.4											
		60										15.7	15.3	14.8	14.4	13.9	13.3	12.8	12.2	11.6	10.9	10.1	8.1	5.6											
Shut-off PSI						197	188	180	171	162	154	144	136	128	119	110	93	76	58	41	24	6													
10GS20	2	0														16.0	15.7	14.9	14.2	13.4	12.4	11.4	10.0	8.2	5.8										
		20														15.9	15.5	15.3	14.8	14.1	13.2	12.2	11.0	9.9	8.0	5.2									
		30														15.8	15.4	15.1	14.7	14.4	13.5	12.7	11.7	10.3	8.8	6.5									
		40														15.8	15.4	15.1	14.7	14.4	14.0	12.9	12.2	10.9	9.5	7.8	3.9								
		50														16.1	15.7	15.3	15.0	14.6	14.2	14.0	13.4	12.5	11.5	10.1	8.5	6.0							
		60														16.0	15.7	15.3	14.9	14.5	14.2	13.8	13.4	12.8	11.8	10.7	9.1	7.2	3.4						
Shut-off PSI										225	216	208	199	190	182	173	164	156	139	121	104	87	69	52	35	17									
10GS30	3	0																			15.8	15.2	14.6	14.0	13.3	12.6	11.9	11.0	10.0	9.0	7.5	5.8			
		20																			15.7	15.1	14.5	13.9	13.2	12.5	11.8	10.9	9.9	8.8	7.2	5.4			
		30																			15.9	15.4	14.8	14.2	13.4	12.8	12.0	11.3	10.3	9.3	8.1	6.2	3.8		
		40																			15.9	15.6	15.0	14.4	13.8	13.1	12.4	11.5	10.8	9.7	8.6	7.1	4.7		
		50																			16.0	15.8	15.6	15.3	14.7	14.1	13.3	12.7	11.9	11.0	10.2	9.1	7.8	6.0	3.0
		60																			16.0	15.8	15.5	15.2	14.8	14.3	13.7	12.9	12.3	11.4	10.6	9.6	8.3	6.8	4.5
Shut-off PSI																284	275	267	258	249	232	215	197	180	163	145	128	111	94	76	59	42	24		

Horsepower Range 5, Recommended Range 3 – 16 GPM, 60 Hz, 3450 RPM

Pump Model	HP	PSI	Depth to Water in Feet/Ratings in GPM (Gallons per Minute)																													
			440	480	520	560	600	640	680	720	760	800	840	880	920	960	1000	1040	1080	1120	1160	1200	1240	1280	1320							
10GS50	5	0						16	15.5	15.2	14.9	14.5	14	13.5	13	12.5	12	11.5	10.8	10.2	9.5	8.5	7	5.2								
		20						15.9	15.4	15.1	14.8	14.5	13.9	13.4	12.9	12.4	11.9	11.3	10.7	10.1	9.4	8.2	6.8	4.3								
		30						15.6	15.2	14.9	14.6	14.2	13.7	13.1	12.6	12.1	11.6	11.0	10.4	9.8	8.8	7.5	6.0	3.0								
		40				15.8	15.3	15.1	14.7	14.4	13.8	13.3	12.8	12.3	11.8	11.2	10.6	10.0	9.2	7.9	6.6	4.1										
		50				15.5	15.2	14.9	14.6	14.1	13.6	13.0	12.5	12.1	11.5	10.9	10.3	9.7	8.6	7.3	5.6											
		60				15.7	15.3	15.0	14.7	14.3	13.7	13.2	12.7	12.2	11.7	11.1	10.5	9.9	9.0	7.7	6.5	3.2										
Shut-off PSI					346	329	312	294	277	260	242	225	208	191	173	156	139	121	104	87	69	52	35	17								

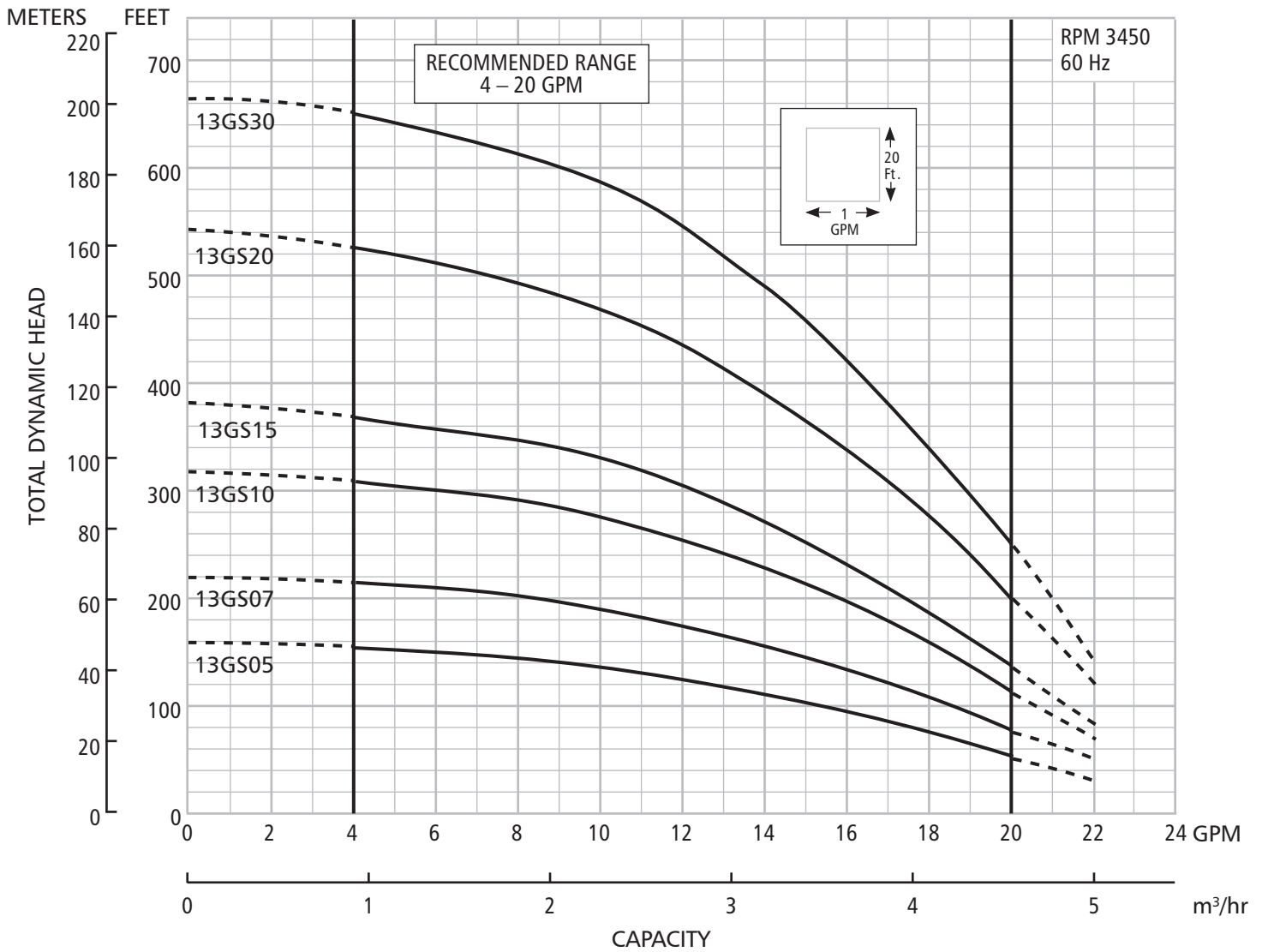

DIMENSIONS AND WEIGHTS

Model	HP	Phase	Stages	Length (inches)			Weight (lbs.)		
				W.E.②	Motor	L.O.A.③	W.E.	Motor	Total
13GS05412,22,11,21	½	1	5	9.6	9.5	19.1	6	19	25
13GS07412,22	¾	1	7	11.0	10.7	21.7	6	21	27
13GS10412,22	1	1	10	13.0	11.8	24.8	7	24	31
13GS15412	1½	1	12	14.4	13.6	28.0	8	28	36
13GS15422	1½	1	12	14.4	15.1	29.5	8	31	39
13GS15432,34	1½	3	12	14.4	11.8	26.2	8	24	32
13GS20412	2	1	17	17.9	15.1	33.0	10	33	43
13GS20432,34	2	3	17	17.9	13.6	31.5	10	28	38
13GS30412	3	1	21	20.6	19.1	39.7	12	41	53
13GS30432,34	3	3	21	20.6	16.1	36.7	12	35	47

② W.E. = water end or pump without motor.

③ L.O.A. = length of assembly – complete pump – water end and motor.

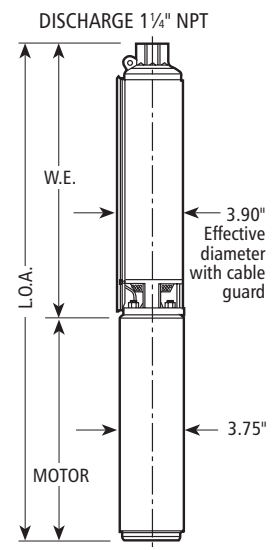

SELECTION CHART

Horsepower Range ½ – 3, Recommended Range 4 – 20 GPM, 60 Hz, 3450 RPM

Pump Model	HP	PSI	Depth to Water in Feet/Ratings in GPM (Gallons per Minute)																														
			20	40	60	80	100	120	140	160	180	200	220	240	260	280	300	340	380	420	460	500	540	580	620	660	700	740	780	820			
13GS05	½	0			19.0	17.5	15.3	12.5	8.2																								
		20	18.8	16.5	14.5	12.0	8.0																										
		30	16.0	13.4	11.0	4.1																											
		40	13.3	10.6	4.0																												
		50	9.8																														
		60																															
Shut-off PSI			60	52	43	35	26	17	9																								
13GS07	¾	0				19.7	18.5	17.0	15.0	13.2	11.5	8.5																					
		20		19.4	18.0	16.4	14.8	12.9	10.5	6.0																							
		30	18.9	17.5	16.0	14.6	12.5	10.0	5.0																								
		40	17.4	15.9	14.4	12.4	9.7	4.0																									
		50	15.4	13.8	12.0	9.5																											
		60	13.2	11.5	8.5																												
Shut-off PSI			86	78	69	61	52	43	35	26	17	8																					
13GS10	1	0						19.6	18.4	17.6	16.6	15.4	14.1	12.8	11.4	9.5	6.0																
		20			20.0	19.4	18.5	17.2	16.3	15.0	13.8	12.5	11.0	8.5	4.0																		
		30		20.0	19.2	18.2	17.1	15.8	14.7	13.6	12.2	10.5	7.5																				
		40	19.9	19.0	18.0	17.0	15.7	14.6	13.5	12.0	10.1	7.3																					
		50	18.8	17.8	16.8	15.5	14.5	13.0	11.6	9.9	7.0																						
		60	17.6	16.6	15.4	14.1	12.8	11.4	9.5	6.0																							
Shut-off PSI			128	119	110	102	93	84	76	67	58	50	41	32	24	15	6																
13GS15	1½	0							19.7	18.9	18.2	17.3	16.3	15.2	14.2	13.2	12.1	8.7															
		20					19.5	18.4	17.9	17.0	16.0	15.1	14.1	12.9	11.8	10.2	8.8																
		30			20.2	19.4	18.6	17.6	16.8	15.8	14.9	14.0	12.6	11.5	9.9	7.9	4.0																
		40		20.0	19.3	18.5	17.5	16.6	15.7	14.8	13.9	12.5	11.4	9.5	7.3	4.0																	
		50	20.0	19.1	18.3	17.4	16.4	15.5	14.5	13.6	12.3	11.0	9.2	6.3																			
		60	18.9	18.2	17.3	16.3	15.2	14.2	13.3	12.1	11.0	8.7	5.6																				
Shut-off PSI			156	147	139	130	121	113	104	95	87	78	69	61	52	43	35	17															
13GS20	2	0										20.0	19.5	19.0	18.3	17.9	17.2	15.8	14.4	12.6	10.5	7.7											
		20									19.8	19.4	18.8	18.2	17.6	17.0	16.3	15.6	14.1	12.4	10.2	6.8											
		30								19.7	19.3	18.7	18.2	17.4	16.8	16.2	15.5	14.8	13.1	11.1	8.8												
		40						19.6	19.2	18.6	18.1	17.3	16.7	16.1	15.4	14.7	13.8	12.0	9.8	6.0													
		50				20.1	19.5	19.1	18.4	18.0	17.2	16.6	16.0	15.2	14.6	13.7	12.9	10.8	8.5														
		60		20.0	19.5	19.0	18.3	17.9	17.2	16.5	15.8	15.1	14.4	13.6	12.6	11.5	9.2	5.0															
Shut-off PSI				206	198	189	180	172	163	155	146	137	129	120	111	103	85	68	51	33	16												
13GS30	3	0													19.8	19.4	18.9	18.0	17.1	16.0	14.6	13.5	11.9	10.0	7.3								
		20												19.6	19.2	18.9	18.3	17.9	17.0	15.9	14.7	13.3	11.8	9.7	6.9								
		30											20.0	19.5	19.1	18.8	18.2	17.8	17.4	16.4	15.2	13.9	12.3	10.5	8.3	4.0							
		40									20.0	19.4	19.1	18.7	18.2	17.8	17.3	16.8	15.6	14.5	13.0	11.4	9.5	6.0									
		50							19.9	19.5	19.0	18.6	18.1	17.7	17.2	16.7	16.1	14.9	13.7	12.0	10.1	7.9											
		60						19.8	19.4	18.9	18.5	18.0	17.5	17.1	16.6	16.0	15.4	14.2	12.9	11.0	9.0	5.0											
Shut-off PSI							235	226	217	209	200	191	183	174	165	157	139	122	104	87	70	53	35	18									

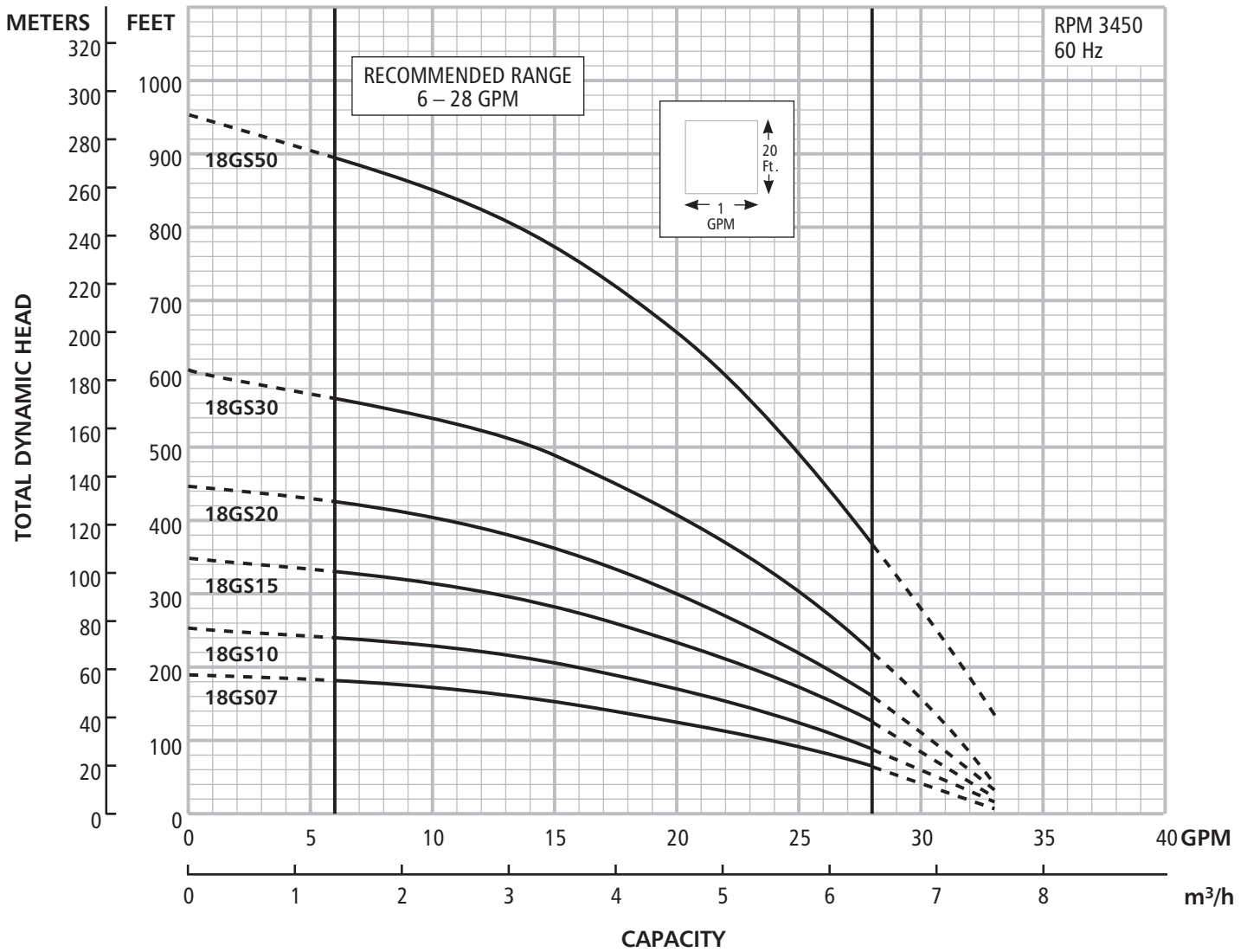

DIMENSIONS AND WEIGHTS

Model	HP	Phase	Stages	Length (inches)			Weight (lbs.)		
				W.E.②	Motor	L.O.A.③	W.E.	Motor	Total
18GS07412,22	¾	1	6	11.3	10.7	22.0	6	21	27
18GS10412,22	1	1	8	13.0	11.8	24.8	7	24	31
18GS15412	1½	1	11	15.5	13.6	29.1	9	28	37
18GS15422	1½	1	11	15.5	15.1	30.6	9	31	40
18GS15432,34	1½	3	11	15.5	11.8	27.3	9	24	33
18GS20412	2	1	14	18.1	15.1	33.2	10	33	43
18GS20432,34	2	3	14	18.1	13.6	31.7	10	28	38
18GS30412	3	1	19	22.4	19.1	41.5	12	41	53
18GS30432,34	3	3	19	22.4	16.1	38.5	12	35	47
18GS50412	5	1	30	32.9	28.2	61.1	17	70	87
18GS50432,34	5	3	30	32.9	22.2	55.1	17	55	72

② W.E. = water end or pump without motor.

③ L.O.A. = length of assembly – complete pump – water end and motor.

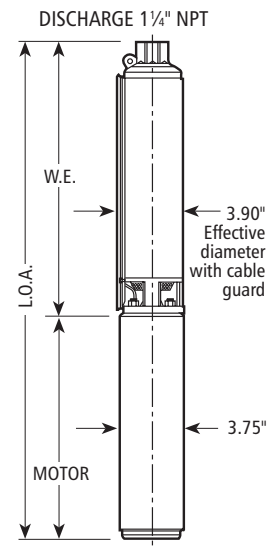

SELECTION CHART

Horsepower Range ¾ – 5, Recommended Range 6 – 28 GPM, 60 Hz, 3450 RPM

Pump Model	HP	PSI	Depth to Water in Feet/Ratings in GPM (Gallons per Minute)																																			
			20	40	60	80	100	120	140	160	180	200	220	240	260	280	300	340	380	420	460	500	540	580	620	660	700	740	780	820	860							
18GS07	¾	0			28.2	26.5	24.0	21.0	17.9	13.5																												
		20	27.7	25.9	23.0	20.0	16.5	10.8																														
		30	25.0	22.0	18.8	15.7	9.5																															
		40	22.2	18.9	15.1	9.0																																
		50	18.4	15.0	7.5																																	
		60	13.5	5.0																																		
Shut-off PSI			74	66	58	49	40	32	23	14																												
18GS10	1	0					27.0	25.5	23.6	21.2	18.8	15.9	12.0																									
		20		28.0	26.6	25.1	22.7	20.0	17.6	14.0	10.0																											
		30	27.9	26.1	24.3	22.2	19.8	17.1	13.8	8.3																												
		40	26.0	24.1	22.0	19.7	17.0	13.1	8.0																													
		50	24.0	22.0	19.1	16.5	13.0	7.1																														
		60	21.0	18.6	15.8	12.0																																
Shut-off PSI			103	94	86	77	68	60	51	42	34	25	16																									
18GS15	1½	0						28.4	27.2	26.0	24.8	23.0	21.4	19.6	17.5	15.0	12.1																					
		20				27.8	26.8	25.4	24.0	22.2	20.6	18.8	16.7	14.0	10.0																							
		30			27.7	26.5	25.3	23.8	22.0	20.2	18.5	16.1	13.5	10.0																								
		40		27.5	26.3	25.0	23.6	22.0	20.1	18.1	16.0	13.1	9.5																									
		50	27.6	26.4	25.0	23.4	21.8	20.0	18.0	15.5	13.0	9.2																										
		60	26.0	24.6	23.0	21.2	19.5	17.5	15.0	12.0	7.9																											
Shut-off PSI			143	134	126	117	108	100	91	82	74	65	56	48	39	30	22																					
18GS20	2	0								28.0	27.1	26.2	25.1	24.0	22.9	21.4	20.0	16.8	12.8																			
		20						27.8	26.8	25.8	24.6	23.7	22.6	21.0	19.5	18.0	16.0	11.6																				
		30					27.5	26.5	25.5	24.5	23.3	22.1	20.6	19.0	17.5	15.8	13.6	6.5																				
		40			28.5	27.4	26.4	25.4	24.4	23.2	22.0	20.5	18.9	17.4	15.7	13.5	11.0																					
		50		28.0	27.2	26.2	25.3	24.3	23.0	21.8	20.3	18.7	17.0	15.3	13.1	10.5	6.0																					
		60	28.0	27.1	26.2	25.1	24.0	22.9	21.4	20.0	18.3	16.8	14.8	12.8	9.5																							
Shut-off PSI			183	174	165	157	148	139	131	122	113	105	96	87	79	70	61	44	27																			
18GS30	3	0											28.0	27.4	26.7	26.0	25.0	23.5	21.5	19.2	16.9	14.2	10.5															
		20										27.7	27.0	26.3	25.8	24.9	24.0	23.0	21.0	18.9	16.5	13.5	9.0															
		30										27.6	26.9	26.2	25.5	24.8	23.9	22.9	21.9	19.8	17.5	14.9	11.2															
		40										27.5	26.9	26.2	25.4	24.6	23.8	22.8	21.8	20.9	18.5	16.0	13.3	8.0														
		50							27.4	26.8	26.0	25.2	24.5	23.6	22.6	21.7	20.6	19.5	17.3	14.5	11.0																	
		60				28.0	27.4	26.7	26.0	25.0	24.3	23.5	22.5	21.5	20.5	19.2	18.0	15.7	12.8	7.0																		
Shut-off PSI					225	216	208	199	190	182	173	164	156	147	139	130	113	95	78	61	43	26																
18GS50	5	0																	27.9	26.8	25.8	24.8	23.7	22.6	21.2	19.9	18.4	16.8	14.8	12.4	9.7							
		20																		27.5	26.6	25.6	24.5	23.3	22.2	21.0	19.8	18.0	16.2	14.3	12.0	8.8						
		30																			28.0	26.9	26.0	25.0	23.9	22.9	21.6	20.3	18.6	17.0	15.0	13.0	10.2	6.2				
		40																				28.0	27.4	26.3	25.3	24.4	23.2	22.1	20.1	19.4	17.9	16.0	14.0	11.6	8.0			
		50																				27.9	27.3	26.8	25.9	24.9	23.8	22.7	21.3	20.1	18.5	16.9	14.9	12.8	10.0	6.0		
		60																				27.9	27.2	26.8	26.2	25.2	24.1	23.0	21.9	20.7	19.2	17.5	15.8	13.6	11.0	7.8		
Shut-off PSI																					307	298	290	281	264	246	229	212	195	177	160	143	125	108	91	73	56	39

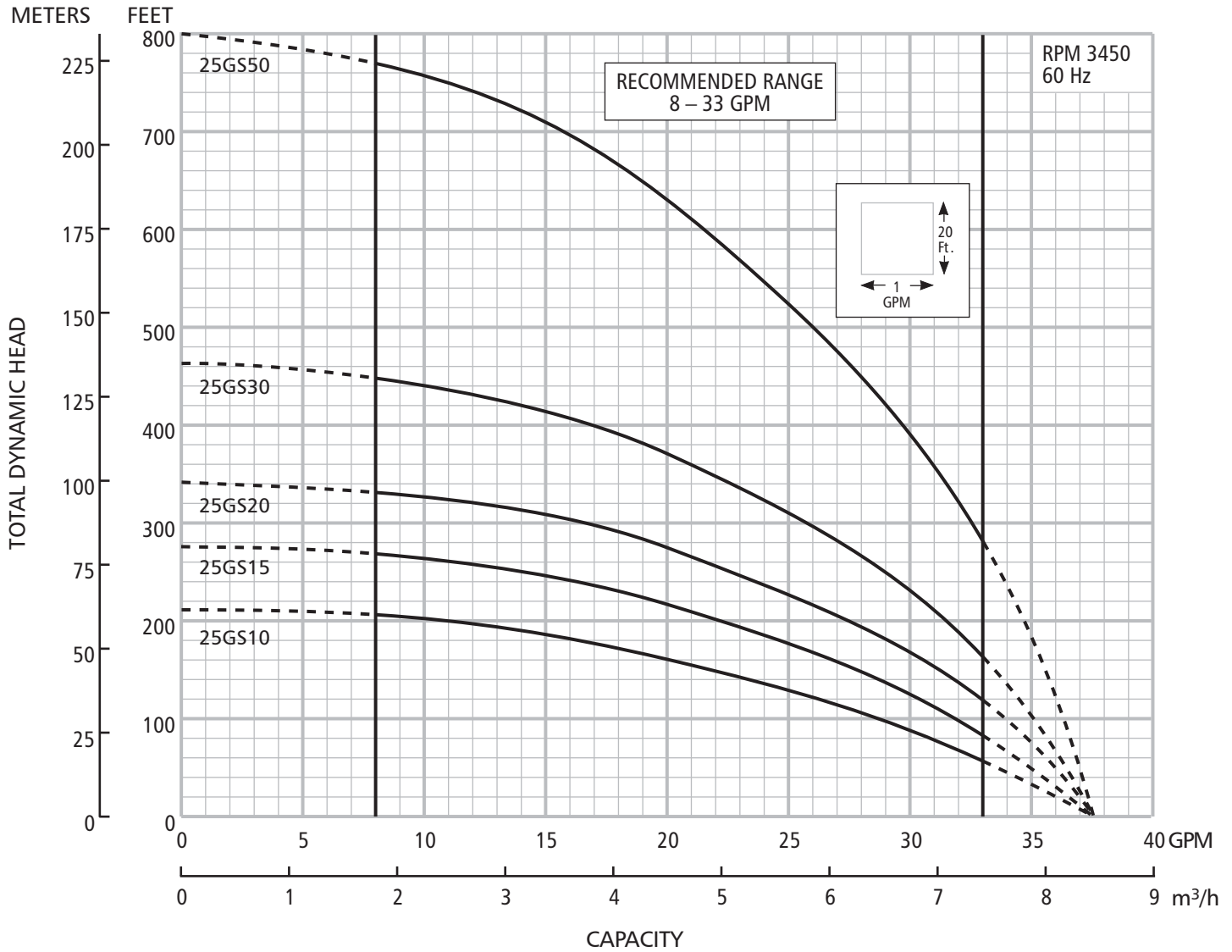

DIMENSIONS AND WEIGHTS

Model	HP	Phase	Stages	Length (inches)			Weight (lbs.)		
				W.E.②	Motor	L.O.A.③	W.E.	Motor	Total
25GS10412,22	1	1	7	12.7	11.8	24.5	7	24	31
25GS15412	1½	1	9	14.6	13.6	28.2	8	28	36
25GS15422	1½	1	9	14.6	15.1	29.7	8	31	39
25GS15432,34	1½	3	9	14.6	11.8	26.4	8	24	32
25GS20412	2	1	11	16.5	15.1	31.6	9	33	42
25GS20432,34	2	3	11	16.5	13.6	30.1	9	28	37
25GS30412	3	1	15	20.2	19.1	39.3	11	41	52
25GS30432,34	3	3	15	20.2	16.1	36.3	11	35	46
25GS50412	5	1	26	31.8	28.2	60.0	17	70	87
25GS50432,34	5	3	26	31.8	22.2	54.0	17	55	72

② W.E. = water end or pump without motor.

③ L.O.A. = length of assembly – complete pump – water end and motor.

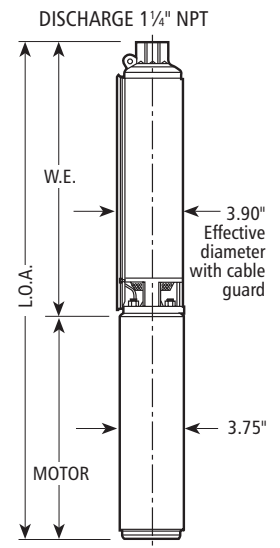

SELECTION CHART

Horsepower Range 1 – 5, Recommended Range 8 – 33 GPM, 60 Hz, 3450 RPM

Pump Model	HP	PSI	Depth to Water in Feet/Ratings in GPM (Gallons per Minute)																											
			20	40	60	80	100	120	140	160	180	200	220	240	260	280	300	340	380	420	460	500	540	580	620	660	700	740		
25GS10	1	0			32.8	30.8	28.6	26.2	23.5	20.0	16.2	11.0																		
		20	31.8	30.0	27.5	25.2	22.0	19.0	15.0	8.0																				
		30	29.6	27.2	25.0	21.6	18.0	14.0																						
		40	27.1	24.9	21.5	17.9	13.9																							
		50	24.3	21.0	17.5	13.0																								
		60	20.0	16.2	11.0																									
Shut-off PSI			82	74	65	56	48	39	30	22	13	4																		
25GS15	1½	0				33.0	31.8	30.3	28.8	26.9	24.8	22.0	19.8	16.5	11.0															
		20		32.6	31.2	29.6	28.0	26.0	23.8	21.0	18.1	14.8	8.0																	
		30	32.5	31.0	29.5	27.6	25.6	23.2	20.9	17.9	14.0																			
		40	30.9	29.4	27.5	25.5	23.1	20.8	17.7	13.6																				
		50	29.0	27.2	25.1	22.9	20.4	17.2	13.0																					
		60	26.9	24.8	22.0	19.8	16.5	11.0																						
Shut-off PSI			111	103	94	85	77	68	59	51	42	33	25	16	7															
25GS20	2	0					33.0	31.8	30.4	29.0	27.4	25.7	22.6	21.5	19.3	15.4														
		20				32.7	31.3	30.0	28.6	26.8	25.0	22.9	20.9	18.3	14.3	9.0														
		30			32.3	31.0	29.6	28.5	26.4	24.5	22.6	20.5	18.0	14.0	8.0															
		40			30.9	29.5	28.2	26.3	24.3	22.4	20.4	17.8	13.6	8.0																
		50		30.5	29.4	28.0	26.0	24.1	22.1	20.0	17.2	13.2																		
		60	30.4	29.0	27.4	25.7	22.6	21.5	19.3	15.4	12.2																			
Shut-off PSI			139	130	121	113	104	95	87	78	69	61	52	43	35	26	17													
25GS30	3	0							33.0	32.2	31.5	30.5	29.6	28.3	27.1	25.8	22.6	19.0	14.0											
		20						32.8	32.0	31.0	30.0	29.0	27.9	26.6	25.0	23.8	21.9	20.0	12.6											
		30					32.6	31.8	30.9	30.0	28.8	27.6	26.5	24.9	23.4	21.6	19.9	15.2	8.0											
		40				32.5	31.7	30.9	29.9	28.8	27.5	26.2	24.7	23.3	21.5	19.9	17.8	11.9												
		50			32.3	31.6	30.8	29.8	28.5	27.3	26.0	24.5	23.0	21.2	19.5	17.4	11.5													
		60	33.0	32.2	31.5	30.5	29.6	28.3	27.1	25.8	24.1	22.6	20.9	19.0	16.9	14.0	10.0													
Shut-off PSI			191	183	174	165	157	148	139	131	122	113	105	96	87	79	70	53	35	18										
25GS50	5	0														33.0	32.5	31.5	30.2	29.0	27.6	26.0	24.2	22.4	20.5	18.3	15.8	12.0		
		20														32.9	32.3	31.8	31.3	30.0	28.8	27.2	25.8	23.9	22.0	20.0	17.8	15.0	11.0	
		30														32.8	32.2	31.8	31.2	30.5	29.3	27.9	26.4	24.8	22.9	21.0	18.9	16.2	13.0	8.0
		40														32.7	32.1	31.7	31.1	30.4	29.9	28.5	27.1	25.4	23.7	21.9	19.9	17.5	14.5	10.5
		50														32.6	32.1	31.6	31.0	30.3	29.9	29.2	27.8	26.3	24.5	22.6	21.8	18.7	16.0	12.7
		60								33.0	32.5	32.0	31.5	30.8	30.2	29.8	29.0	28.3	26.9	25.1	23.3	21.5	19.5	17.0	14.0	9.5				
Shut-off PSI								286	277	268	260	251	242	234	225	216	199	182	165	147	130	113	95	78	61	43	26			

Repair Parts

MODEL

GS

Item No.	Description	Current Models ③								
		HP	5GS	7GS	10GS	13GS	18GS	25GS		
	NUMBER OF STAGES	½R	9	7	5	—	—	—		
		½	12	10	7	5	—	—		
		¾	15	13	10	7	6	—		
		1	20	17	12	10	8	7		
		1½	26 ①	22	17	12	11	9		
		2	33 ②	27 ②	20	17	14	11		
		3	—	34 ②	27 ②	21	19	15		
		5	—	—	42 ②	—	30 ②	26 ②		
1-4	Discharge head assembly	7K2077	7K2077	7K2077	7K2077	7K2077	7K2077			
2	Check valve poppet	7K1366	7K1366	7K1366	7K1366	7K1366	7K1366			
3	C.V. seal/seat assembly	7K2123	7K2123	7K2123	7K2123	7K2123	7K2123			
4	C. V. retaining ring	7K1364	7K1364	7K1364	7K1364	7K1364	7K1364			
5	Bearing spider – upper	7K1372	7K1372	7K1372	7K1372	7K1372	7K1372			
6	Bearing	7K1740	7K1740	7K1740	7K1740	7K1740	7K1740			
7	Shaft retaining ring – upper	7K817	7K817	7K817	7K817	7K817	7K817			
8	Diffuser	7K1750	7K995	7K17	7K17	7K20	7K20			
9	Upthrust washer	7K15	7K15	7K15	—	7K15	7K15			
10	Impeller 7GS ½ hp - 1½ hp	7K1837	7K1343	7K35	7K16	7K1334	7K19			
10	Impeller 7GS 2 and 3 hp	—	7K994	—	—	—	—			
11	Bowl	7K1838	7K478	7K478	7K478	7K858	7K18			
12A ①	Intermediate shaft sleeve	7K209	—	7K209	—	7K209	7K209			
12B ②	Intermediate shaft sleeve	④	④	④	—	④	—			
13A ①	Intermediate bearing spider	7K1371	—	—	—	—	—			
13B ②	Intermediate bearing spider	7K1989	7K1989	7K1989	—	7K1989	7K1989			
14	Mid bearing for 13A & 13B	7K1369	7K1369	7K1369	—	7K1369	7K1369			
15	Shim	7K155	7K155	7K155	7K155	7K155	7K155			
16	Lower shaft sleeve	7K1336	7K1336	7K1336	7K1336	7K1336	7K1336			
17	Inlet strainer	7K1370	7K1370	7K1370	7K1370	7K1370	7K1370			
18	Screws – cable guard	13K91	13K91	13K91	13K91	13K91	13K91			
19	Hex nut	13K114	13K114	13K114	13K114	13K114	13K114			
20	Motor adapter	7K1363	7K1363	7K1363	7K1363	7K1363	7K1363			
21	Lower shaft retaining ring	—	7K1553	7K1553	—	7K1553	—			
22	Motor lead insulator	7K1023	7K1023	7K1023	7K1023	7K1023	7K1023			
23	Casings	½R	7K1968	7K1913	7K1902	—	—	—		
		½	7K1938	7K1936	7K1905	7K1902	—	—		
		¾	7K1941	7K1939	7K1935	7K1905	7K1964	—		
		1	7K1949	7K1973	7K1938	7K1935	7K1935	7K1914		
		Upper Lower	1½	7K1954	7K1951	7K1944	7K1938	7K1939	7K1943	
			—	—	—	—	—	—	—	
		Upper Lower	2	7K1453	7K1958	7K1949	7K1944	7K1945	7K1941	
			7K1452	—	—	—	—	—	—	
		Upper Lower	3	—	7K1973	7K1946	7K1950	7K1952	7K1479	
			—	7K1453	7K1943	—	—	—	—	
		Upper Lower	5	—	—	7K1971	—	7K1948	7K1947	
			—	—	7K1636	—	7K1738	7K1453	—	
		24	Shaft and coupling assemblies	½R	7K1033	7K1361	7K1358	—	—	—
				½	7K1377	7K1376	7K1360	7K1358	—	—
¾	7K1381			7K1380	7K1375	7K1360	7K1359	—		
1	7K1458			7K1384	7K1377	7K1375	7K1375	7K1374		
Upper Lower	1½			7K1839	7K1839	7K1457	7K1377	7K1380	7K1378	
	—			—	—	—	—	—	—	
Upper Lower	2			7K1877	7K1391	7K1458	7K1457	7K1382	7K1381	
	7K1879			—	—	—	—	—	—	
Upper Lower	3			—	7K1462	7K1878	7K1386	7K1387	7K1385	
	—			7K1213	7K1880	—	—	—	—	
Upper Lower	5			—	—	7K1393	—	7K1736	7K2212	
	—			—	7K1221	—	7K1737	7K2211	—	
25	Cable guards			½R	7K1885	7K1883	7K1881	—	—	—
				½	7K1888	7K1886	7K1883	7K1881	—	—
		¾	7K1890	7K1889	7K1886	7K1883	7K1883	—		
		1	7K1917	7K1916	7K1888	7K1886	7K1886	7K1886		
		1½	7K1922	7K1919	7K1916	7K1888	7K1889	7K1888		
		2	7K1927	7K1924	7K1917	7K1916	7K1916	7K1890		
		3	—	7K1929	7K1923	7K1918	7K1920	7K1917		
		5	—	—	7K1931	—	7K1930	7K1929		

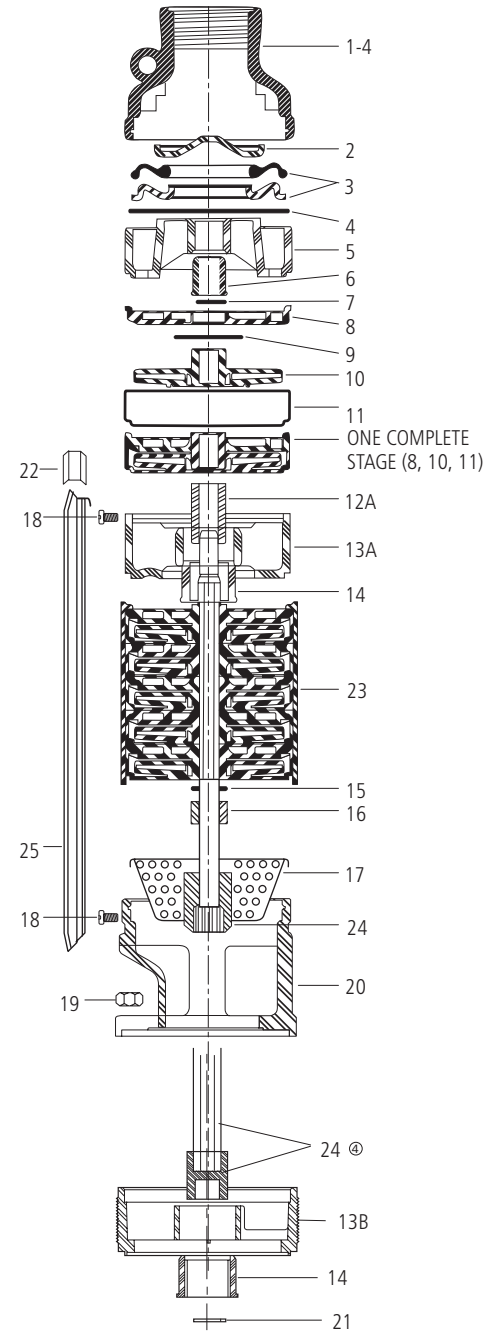

- ① Model has one intermediate bearing spider, order bearing and spider separately.
- ② Model has one intermediate bearing spider, a split case design and upper and lower shaft assemblies.
- ③ Current GS pumps are identified by 4 cable guard screws.
- ④ Intermediate Shaft Sleeve 7K1490 is now a pressed on part of the upper shaft assembly on split case pumps.

